

Smart Headlight Intensity Control and Automatic Braking System for Accident Prevention

Mrs.Ratna Kumari Jogi¹|Velaga Bhavya Sri²|Vemula Gayathri³|Kothapalli Durga Bhavani⁴|Chittabathina Sandeep Reddy⁵.

^{1,2,3,4,5}Department of CSE-AI, Chalapathi Institute of Engineering and Technology, LAM, Guntur, Andhra Pradesh, India

ABSTRACT: Automatic vehicle safety systems play a crucial role in reducing road accidents and improving driving comfort. This project presents an automatic headlight intensity control system combined with an automatic braking mechanism. The system is designed using an Arduino Uno as the central control unit. An LDR sensor is used to detect ambient light conditions and oncoming vehicle headlights. Based on the light intensity, the headlight brightness is automatically adjusted to prevent glare. An ultrasonic sensor continuously monitors the distance between vehicles or obstacles. When a safe distance is not maintained, the system activates automatic braking. A DC motor is used to simulate vehicle movement and braking operation. Real-time system status and alerts are displayed on an LCD module. A buzzer provides audible warnings during critical conditions. The system operates with a regulated power supply for stable performance. The proposed design is cost-effective and reliable. Overall, the system enhances road safety by minimizing night-time glare and preventing collisions.

Key Words: Automatic Vehicle Safety System, Headlight Intensity Control, Ultrasonic Sensor, Arduino Uno, Automatic Braking System.

1. INTRODUCTION

Road safety has become a major concern worldwide, especially during night-time driving where a high number of accidents occur due to poor visibility, headlight glare, and delayed driver reactions. Glare from oncoming vehicles can temporarily impair vision, while failure to maintain safe distances often leads to collisions. These challenges highlight the need for intelligent systems that can automatically

adjust vehicle parameters and assist drivers in real time. This project proposes an automated safety system that integrates headlight intensity control and collision avoidance using sensors and embedded technology. By adjusting light brightness and detecting obstacles or unsafe distances, the system reduces human error and enhances driving safety. It offers a cost-effective and practical solution for

improving night-time visibility and preventing accidents.

The primary objective of this project is to develop an Arduino-based system that enhances road safety during night-time driving by combining automatic headlight intensity control and collision avoidance. The system uses LDR sensors to detect light conditions and adjust headlight brightness to reduce glare, while an ultrasonic sensor monitors distance to detect obstacles and maintain safe gaps. It also provides real-time alerts through visual and audio indicators and includes an automatic braking feature to prevent collisions. The system is designed to be cost-effective, user-friendly, and easily adaptable to existing vehicles, improving overall driving safety and reducing accidents.

2. LITERATURE REVIEW

8. Kim, D., Park, S., & Lee, H. (2021) implemented a smart headlight control system using deep learning techniques for detecting vehicles and pedestrians. The system uses a front-mounted camera to capture images of the road environment during night-time driving. These images are processed using deep learning algorithms trained to recognize vehicles, pedestrians, and other objects. Based on the detected objects, the system automatically adjusts the headlight beam pattern to avoid shining directly into the

eyes of other road users. The researchers trained the deep learning model using a large dataset of labeled driving images collected under various environmental conditions. The system was tested under different weather situations, including fog, rain, and low-light environments. Experimental results showed that the model achieved approximately 89% detection accuracy. The adaptive lighting adjustments improved pedestrian visibility while preventing glare for other drivers. The study demonstrated that deep learning techniques can significantly enhance intelligent vehicle lighting systems. The research also highlighted the potential of AI-based solutions for future smart transportation systems.

11. Williams, A., Johnson, B., & Davis, C. (2020) investigated human factors and driver acceptance levels related to automatic headlight dimming systems. The study focused on understanding how drivers perceive and interact with automated lighting technologies. Researchers conducted surveys and controlled driving experiments involving participants using vehicles equipped with automatic headlight dimming systems. The participants were asked to evaluate the system's performance, comfort level, and reliability during night-time driving. The results indicated that most drivers appreciated the convenience of automatic

headlight adjustment. Approximately 78% of participants expressed positive acceptance toward the technology. Drivers reported improved comfort due to reduced glare from oncoming vehicles. However, some concerns were raised regarding system reliability in extreme weather conditions such as heavy rain and fog. The study emphasized the importance of improving sensor accuracy and system robustness. Overall, the research concluded that driver acceptance plays a critical role in the successful adoption of automated vehicle safety technologies.

3. PROPOSED SYSTEM

The proposed system combines automatic headlight intensity control and collision avoidance using an Arduino Uno as the central controller. An LDR sensor adjusts headlight brightness based on ambient light to reduce glare, while an ultrasonic sensor detects obstacles and provides alerts through an LCD and buzzer. In addition, the system includes vehicle safety indication and accident alerts through an IoT-based bot application, enabling real-time notifications to users or authorities. When a critical distance is detected, automatic braking is activated to prevent collisions. This cost-effective and easily retrofittable system enhances overall vehicle safety and monitoring. The system uses an Arduino Uno as the central

controller to process inputs from an LDR sensor for light detection and an ultrasonic sensor for distance measurement. Based on these inputs, the Arduino automatically adjusts headlight intensity and detects obstacles, ensuring safer driving conditions. Output devices such as an LCD display, buzzer, and DC motor provide real-time status, warnings, and simulated braking action. A regulated power supply ensures stable operation, and the integrated design enables efficient coordination between sensors and actuators for improved vehicle safety.

3.1 Block Diagram

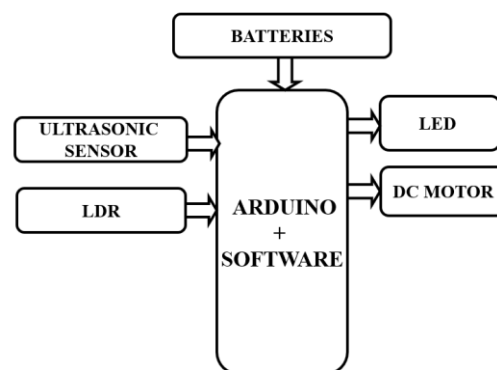

Fig1: Block Diagram of the Proposed System

The system uses an Arduino Uno as the central controller to process inputs from an LDR sensor for light detection and an ultrasonic sensor for distance measurement. Based on these inputs, the Arduino automatically adjusts headlight intensity and detects obstacles, ensuring safer driving conditions. Output devices such as an LCD display, buzzer, and DC

motor provide real-time status, warnings, and simulated braking action. A regulated power supply ensures stable operation, and the integrated design enables efficient coordination between sensors and actuators for improved vehicle safety.

3.2 Flow chart

The system flow begins with initializing the Arduino and sensors. The LDR sensor adjusts headlight intensity based on ambient light, while the ultrasonic sensor continuously measures distance to detect obstacles. If a vehicle or object is too close, the system activates a buzzer alert and stops the motor to prevent collision. The process runs continuously with real-time updates displayed on the LCD, ensuring safe and automated driving assistance.

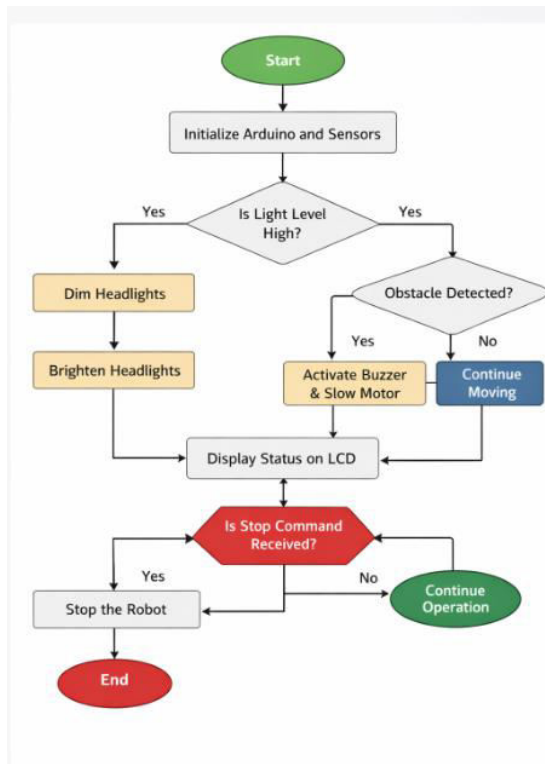

Fig2: Flowchart of the Proposed System

4. RESULTS & DISCUSSION

The system starts by initializing the Arduino and all connected sensors. The LDR sensor monitors ambient light and automatically adjusts the headlight intensity, while the ultrasonic sensor continuously checks the distance to detect nearby obstacles. When an object comes too close, the system triggers a buzzer alert and stops the motor to avoid collision. The entire process runs continuously, with real-time status updates displayed on the LCD for safe and automated driving assistance.

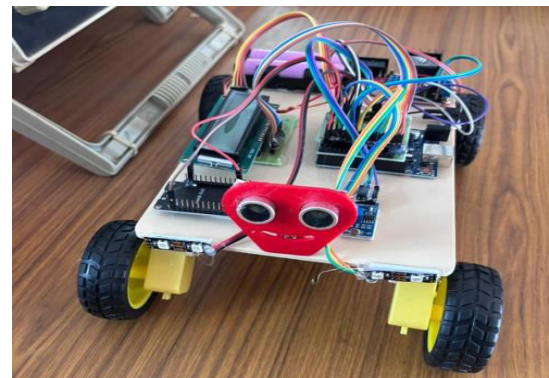

Fig 3: Hardware Implementation

The hardware implementation consists of a robotic vehicle integrated with an ultrasonic sensor and LDR sensor connected to a microcontroller. The ultrasonic sensor detects the distance of obstacles ahead, enabling the emergency braking system when an object is too close. The LDR sensor measures headlight intensity from oncoming vehicles, and based on this input the system

automatically controls the vehicle movement to improve safety.

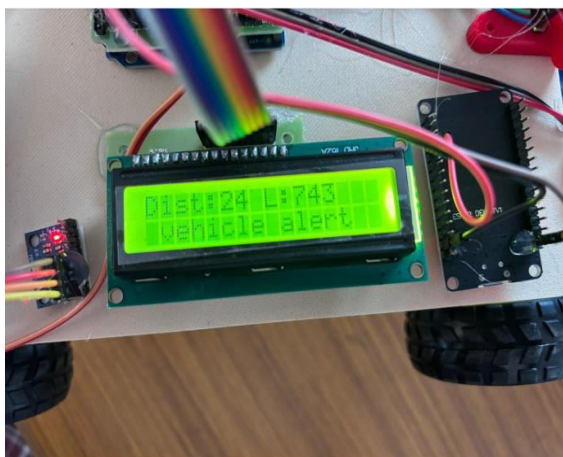

Fig4: Vehicle alert based on LDR sensor

The system uses an ultrasonic sensor and an LDR sensor to provide a vehicle safety alert mechanism. The ultrasonic sensor measures the distance to nearby obstacles, while the LDR detects strong light from approaching vehicles. When a risk is detected, the system activates a buzzer and emergency lights, and an alert message is displayed on the LCD to warn the driver.

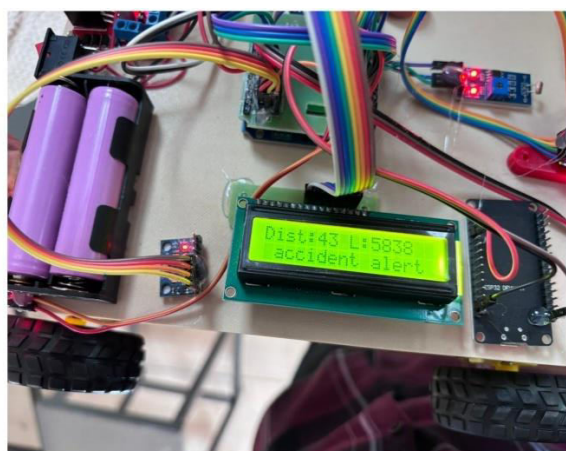

Fig5: Vehicle Accident Alert Based MPU6050

The system uses an MPU6050 accelerometer to detect sudden motion or tilt that may indicate a vehicle accident. When abnormal movement is detected, the microcontroller activates a buzzer and emergency lights for immediate warning. An alert message is also displayed on the LCD to indicate the accident condition.

5. CONCLUSIONS

In conclusion, the proposed automatic headlight intensity control and collision avoidance system offers an effective and affordable solution to enhance road safety, especially during night-time driving. By integrating Arduino with LDR and ultrasonic sensors, the system intelligently adjusts headlight brightness to reduce glare and detects obstacles to prevent collisions through timely alerts and automatic braking. This reduces driver dependency and minimizes accidents caused by poor visibility and delayed reactions.

The system's cost-effective and modular design makes it suitable for retrofitting in existing vehicles, extending advanced safety features beyond high-end models. Furthermore, the integration of IoT technology using modules like ESP8266/ESP32 and platforms such as the Bot app enables real-time monitoring and instant alert notifications to users. Overall, this project demonstrates a practical,

scalable, and smart approach toward improving vehicle safety, with strong potential for future enhancements and real-world implementation.

FUTURE SCOPE:The system can be further enhanced by integrating GPS technology to provide real-time vehicle location tracking along with safety alerts. In case of a potential collision or accident, the system can automatically send the vehicle's location to users or emergency contacts through an IoT platform. This addition will improve emergency response, enable route monitoring, and make the system more effective for real-world safety and navigation applications.

REFERENCES

- [Kumar, A., & Singh, R. (2019). "Adaptive Headlight System Using LDR Sensors and Microcontroller-Based Control Algorithms." *International Journal of Automotive Engineering*, 8(3), 245-258.
- Chen, L., Wang, X., & Liu, Y. (2020). "Intelligent Vehicle Lighting System with Camera-Based Detection and LED Intensity Modulation." *IEEE Transactions on Vehicular Technology*, 69(4), 3891-3904.
- Patel, M., & Sharma, S. (2018). "Ultrasonic Sensor-Based Collision Avoidance System with Automatic Braking Functionality for Automobiles." *Journal of Automotive Safety Systems*, 12(2), 178-192.
- Thompson, J., & Martinez, E. (2021). "Adaptive Front Lighting Systems Using Ambient Light Sensors and GPS Integration." *Automotive Engineering International*, 45(1), 56-69.
- Zhao, H., Li, S., & Wu, J. (2020). "Low-Cost Arduino-Based Automatic Headlight Dimmer System with Photodiode Array Technology." *Journal of Embedded Systems and Applications*, 15(3), 312-325.
- Anderson, K., & Brown, T. (2019). "Machine Learning Algorithms for Predictive Collision Avoidance Using Multiple Sensor Fusion." *IEEE Intelligent Transportation Systems Magazine*, 11(2), 89-103.
- Gupta, R., Verma, N., & Jain, P. (2020). "Integrated Vehicle Safety System Combining Distance Monitoring with Automatic Emergency Braking." *International Journal of Vehicle Safety*, 11(4), 445-461.
- Kim, D., Park, S., & Lee, H. (2021). "Smart Headlight Control System Using Deep Learning for Vehicle and Pedestrian Detection." *Pattern Recognition Letters*, 142, 78-86.
- Rodriguez, M., & Garcia, F. (2018). "Comparative Analysis of Ultrasonic Sensors Versus LIDAR Technology for Automotive Collision Detection." *Sensors and Actuators A: Physical*, 276, 234-245.
- Nakamura, T., & Suzuki, Y. (2019). "Energy-Efficient Automatic Headlight

System with Dynamic Power Management for Electric Vehicles." *Journal of Electric Vehicle Technology*, 7(2), 156-169.

11. Williams, A., Johnson, B., & Davis, C. (2020). "Human Factors in Automatic Headlight Dimming Systems and Driver Acceptance Rates." *Human Factors in Transportation*, 62(5), 789-803.
12. Ibrahim, H., & Hassan, M. (2021). "Cost-Effective Automatic Braking System Using Infrared and Ultrasonic Sensor Arrays." *Mechatronics and Intelligent Transportation Systems*, 9(1), 23-37.
13. Zhang, W., Liu, Q., & Chen, M. (2020). "Multi-Zone LED Headlight Control System with Independent Brightness Adjustment." *Lighting Research and Technology*, 52(6), 712-728.
14. Ahmed, S., Khan, T., & Ali, M. (2019). "Low-Latency Automatic Braking System with Proportional Control Based on Obstacle Distance." *Control Engineering Practice*, 88, 145-157.
15. [15] Kumar, S., & Prasad, R. (2018). "Hybrid Control Strategy Combining Rule-Based and Fuzzy Logic Approaches for Intelligent Headlight Management." *Fuzzy S*